

STANDARD ACCESSORIES

- ★ Tool Box
- ★ Call Light
- ★ Work Lamp
- ★ Chip Enclosure
- ★ Coolant System
- ★ Guideway Cover
- ★ Screw Conveyor
- ★ Cutting Air Blast
- ★ Auto Lube System
- ★ Movable Electronic Handwheels
- ★ Leveling Blocks And Bolts
- ★ ATC Armless Type 16 Tools
- ★ Mechanical, Electrical & Operating Manual
- ★ Spindle Cooling System (GMC-860 opt.)
- ★ Belt drive Spindle 8000 rpm

OPTIONAL ACCESSORIES

- a. CE
- b. Tranformer
- c. Flood Coolant
- d. Belt drive 10000/(GMC-860, 1020)12000 rpm
- d-1.Direct drive Spindle BT40/HSK63A: 10000/12000/15000/18000 rpm
BT50/HSK100A: 8000/10000/12000 rpm
- d-2.Built-in drive Spindle BT40/HSK63A: 18000/24000/30000 rpm
BT50/HSK100: 8000/10000/12000 rpm
- e. Coolant Thru Spindle C.T.S. 20bar
- f. 4th Axis Rotary Table
- g. Coolant Thru Tool Tip
- h. Chip Conveyor System
- i. TS27R Tool Setting Probe (Length Measurement)
- j. MP10/12 Inspection Probe Kits
- k. ARMLESS A.T.C.: 20/24 TOOLS
- l. (ARM Type)ATC.BT40 24 Tools/ 30 Tools/ 40 Tools
BT50 24 Tools/ 30 Tools
- m. A.T.C. (CHAIN TYPE) Tool to Tool
- o. 2 Speed Gear Box for spindle
- p. Spindle Cooling System
- q. Tailstock & Chuck
- r. Laser tool measuring
- s. Chain Type Chip Conveyor

Remarks: If Chain type ATC installed, the max, tool diameter is 75mm when full pocket.

SPECIFICATION

ITEM	UNIT	GMC-860	GMC-1020	GMC-1160	GMC-1165	GMC-1270	GMC-1470	GMC-1680	GMC-1890	GMC-2090
TABLE										
Table Size	MM(inch)	960 x 460 (37.7"x18.1")	1100 x 510 (43.3"x20")	1200x510 (47.2"x20")	1200 x 650 (47.2"x25.6")	1300x650 (51.2"x25.6")	1500 x 650 (59"x25.6")	1700 x 800 (66.9"x31.5")	1900 x 800 (74.8"x31.5")	2100 x 800 (82.6"x31.5")
Working Area	MM(inch)	860 x 480 (33.8"x18.8")	1020 x 530 (40"x20.9")	1100 x 650 (43.3"x25.6")	1100 x 650 (43.3"x25.6")	1200x650 (47.2"x25.6")	1400 x 650 (55.1"x25.6")	1600 x 800 (63"x31.5")	1800 x 800 (70.8"x31.5")	2000 x 800 (78.7"x31.5")
Tee slots (CD x W x NO)	MM	CD 100x18x4	CD 100x18x4	CD 100x18x5	CD 100x18x5	CD 100x18x5	CD 100x18x5	CD 100x18x8	CD 100x18x8	CD 100x18x8
Table load (maximun)	KG(lbs)	600(1320)	800(1760)	1100(2420)	1100(2420)	1300(2860)	1500(3300)	2000(4400)	2000(4400)	3000(6600)
TRAVEL										
X-axis	MM(inch)	860(33.8")	1020(40")	1100(43.3")	1100(43.3")	1200(47.2")	1400(55.1")	1600(63")	1800(70.8")	2000(78.7")
Y-axis	MM(inch)	480(18.8")	530(21")	650(25.6")	650(25.6")	700(27.6")	700(27.6")	800(31.5")	900(35.4")	900(35.4")
Z-axis	MM(inch)	500(19.6")	600(23.6")	650(25.6")	650(25.6")	650(25.6")	650(25.6")	710(27.9")	710(27.9")	710(27.9")
Spindle nose to table surface	MM(inch)	100-600 (3.9"-23.6")	100-700 (3.9"-27.6")	100-750 (3.9"-29.5")	100-750 (3.9"-29.5")	100-750 (3.9"-29.5")	100-750 (3.9"-29.5")	100-810 (3.9"-31.9")	100-810 (3.9"-31.9")	100-810 (3.9"-31.9")
Spindle center to column surface	MM(inch)	520(20.4")	550(21.6")	680(26.7")	700(27.6")	700(27.6")	700(27.6")	875(34.4")	950(37.4")	950(37.4")
X.Y.Z. Axis Ball screws dia	MM	32xpitch12	40xpitch12	40xpitch12	40xpitch12	40xpitch12	40xpitch12	50xpitch12	50xpitch12	50xpitch12
SPINDLE										
Spindle taper		BT 40, ISO40, CAT40		BT 40, ISO40, CAT40 (Option: BT 50, CAT50)						
Spindle speed - standard access	RPM	Standard: 8000 Option: 10000/12000								
Belt drive		10,000(Standard), 12,000(Option)		BT40:10,000(Standard), BT50: 8000(Option)						
Direct drive Spindle	RPM	BT40/HSK63A: 10000/12000/15000/18000 rpm, BT50/HSK100A: 8000/10000/12000 rpm								
Built-in drive Spindle		BT40/HSK63A: 18000/24000/30000 rpm, BT50/HSK100: 8000/10000/12000 rpm								
FEEDRATE										
Cutting Feedrate (X, Y, Z axis)	MM/MIN	1-10000(Depending Controller)				1-10000(Depending Controller)				
3Axes Slideways		HARDENED GROUND				HARDENED GROUND				
Rapid Traverse Rates (X/Y/Z axis)	M	24 /24 /15				20 /20 /15		15 /15 /15		
ATC										
Capacity-standard access.	PCS	16(Armless) / Option 24 (Arm)				16(Armless)				
Capacity-optional access.(ARM)	PCS	24/30(Disc Type), 32/40(Chain Type)								
Tool Selection		Bi-directional & min.path								
Maximum tool diameter x length	MM(inch)	Armless Type: 89 x 250(3.5"x9.8"), Arm Type: 80 x 250(3.14"x9.8")								
Maximum tool weight	KG(lbs)	6(13.2)								
Air Power required		6KG/cm ²								
Tool Shank		BT40, ISO40 or CAT40 (Option) ISO50 or CAT50								
MOTOR										
Spindle drive Motor	KW(HP)	Standard: 7.5KW(10HP), OPTION: 11KW(15HP), OPTION:2 speed gear box				Standard: 15KW(20HP), OPTION: 2 speed gear box 11KW(15HP)				
Coolant Pump	HP	1/2								
Power Supply		STD: 20KVA				STD: 30KVA				
NET WEIGHT	KG(lbs)	4500(9900)	5300(11600)	5300(11660)	6600(14520)	7100(15600)	7800(17100)	12500(27500)	13500(29700)	17200(37840)

*FOUR SLIDEWAYS ON BASE *All specifications and designs are subject to change without notice.

FullLand®



Feature 4H+1R

- High Precision
- High Rigidity
- High Performance
- High Speed
- Reliable

Awarded as A Proof of Excellence In Technical



Mold making Car industry / 3C industry / Mechanical equipment / Aerospace industry

FullLand®

GEON CHENG TECHNOLOGY CO., LTD.

P.O.BOX 246 FENG YUAN TAICHUNG, TAIWAN
No.78, Sanshe Rd., Shengang Dist. Taichung City 429, Taiwan
TEL: +886-4-25316697 FAX: +886-4-25316657
E-mail Address: geontech@hibox.hinet.net
www.geontech.com.tw

GMC-1890

- TRAVEL
- X: 1800mm (70.8")
- Y: 900mm (35.4")
- Z: 710mm (28")

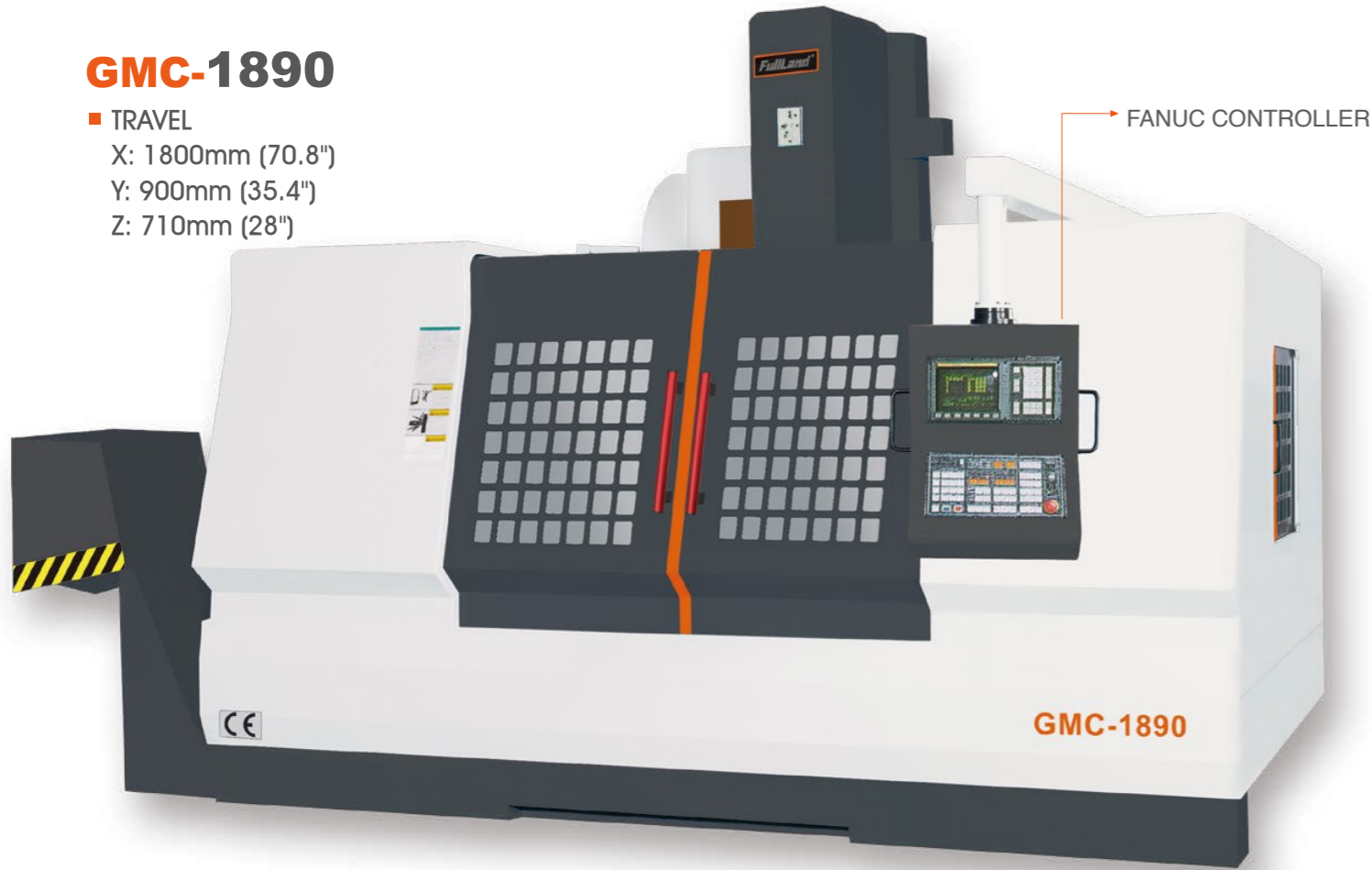

GMC-1470

MITSUBISHI CONTROLLER



- TRAVEL
- X: 1400mm (55.1")
- Y: 700mm (27.6")
- Z: 650mm (25.6")

GMC-860

FAGOR CONTROLLER



- TRAVEL
- X: 860mm (33.8")
- Y: 480mm (18.9")
- Z: 500mm (19.6")

GMC-1165

FANUC CONTROLLER



- TRAVEL
- X: 1100mm (43.3")
- Y: 650mm (25.6")
- Z: 610mm (24")

GMC-1680

- TRAVEL
- X: 1600mm (63")
- Y: 800mm (31.5")
- Z: 710mm (28")

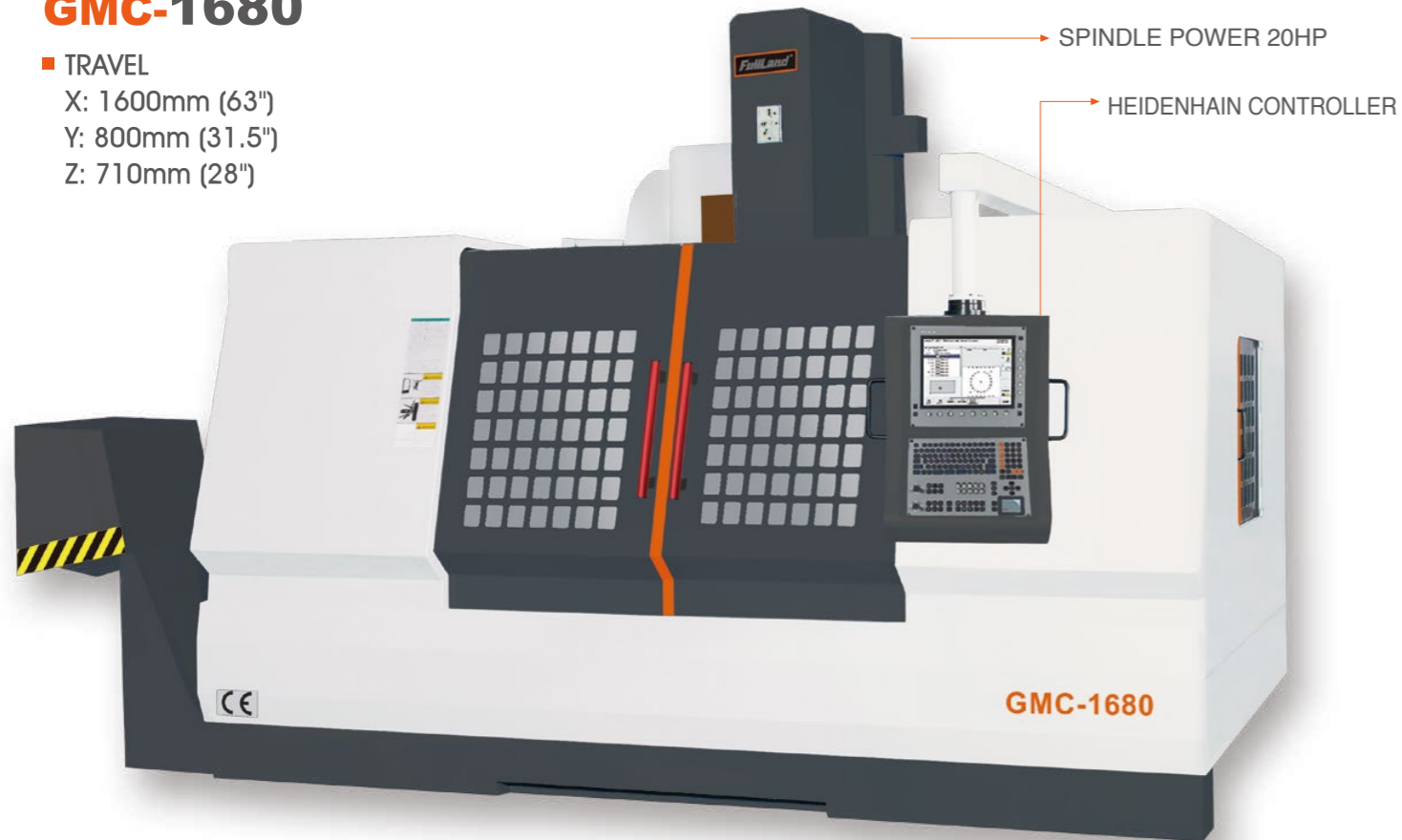

GMC-1270

FANUC CONTROLLER



- TRAVEL
- X: 1200mm (51.1")
- Y: 700mm (27.6")
- Z: 650mm (25.6")

PRODUCT INSPECTION

100% pitch error inspected by Laser unit.

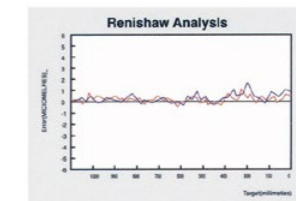

100% dynamic traverse inspected.

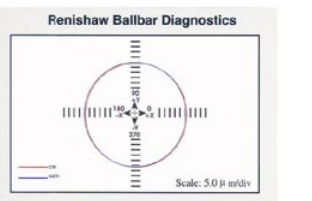

All machines are measured by laser equipment to attain high positioning and repeated accuracy with pitch and backlash compensation.

Reference Standards: VDI 3441



Testing the roundness by the ball bar tester.

COMPUTER AIDED STRUCTURE DESIGN FOR PROCURING THE BEST RIGIDITY

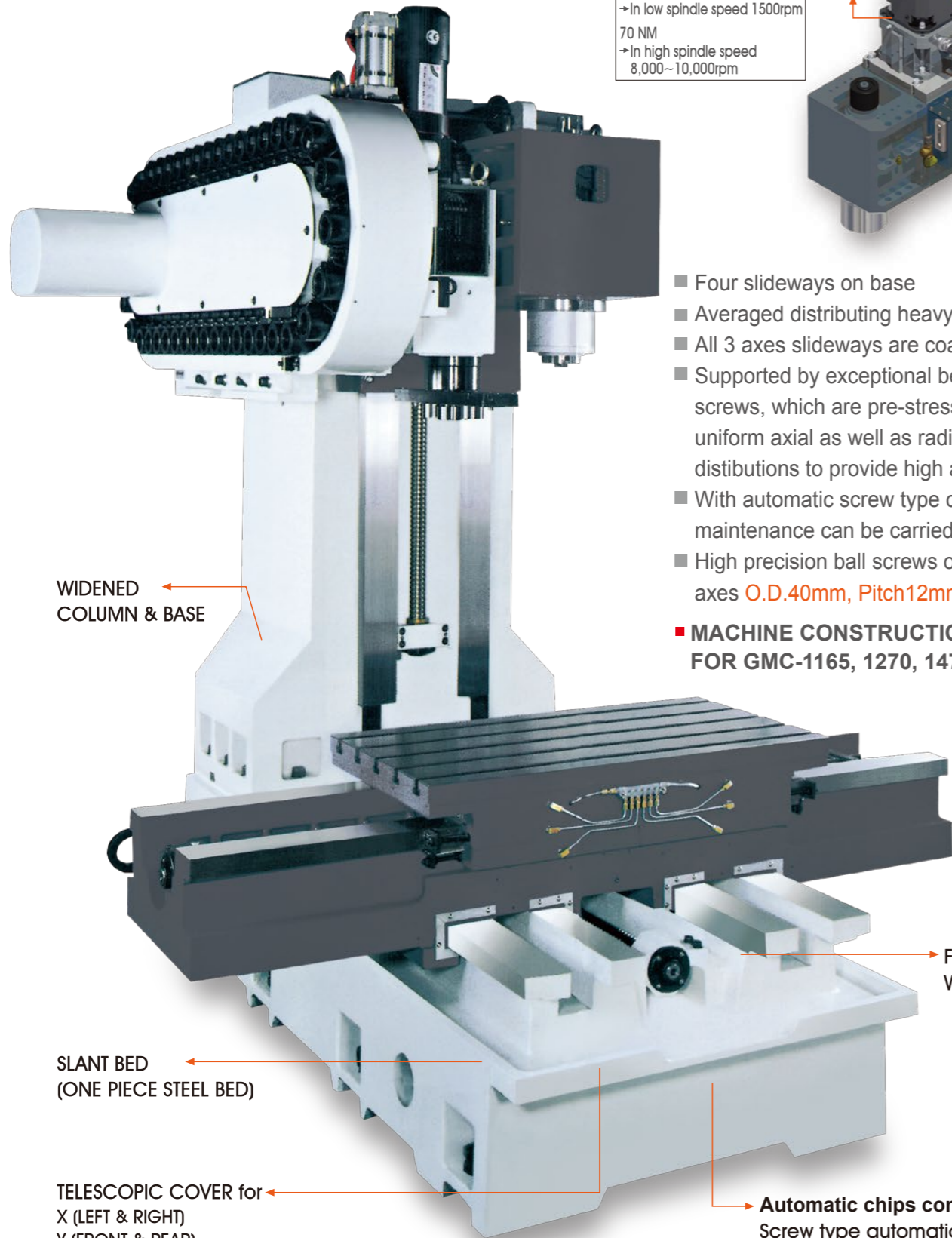

Spindle drive motor (α 12i gear box)-1:4
 280 NM
 → In low spindle speed 1500rpm
 70 NM
 → In high spindle speed 8,000~10,000rpm

WIDENED COLUMN & BASE

SLANT BED (ONE PIECE STEEL BED)

TELESCOPIC COVER for X (LEFT & RIGHT)
 Y (FRONT & REAR)
 Z (DOWN)

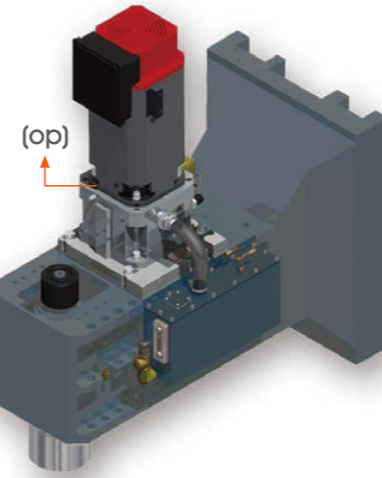

- Four sideways on base
- Averaged distributing heavy loading
- All 3 axes slideways are coated with **Turcite-B**.
- Supported by exceptional bearings and ball screws, which are pre-stressed to generate uniform axial as well as radial force distributions to provide high accuracy.
- With automatic screw type conveyor maintenance can be carried out easily.
- High precision ball screws on all three axes O.D.40mm, Pitch12mm

MACHINE CONSTRUCTION FOR GMC-1165, 1270, 1470

FOUR SLIDE WAYS ON BASE

Automatic chips conveying system
 Screw type automatic chip conveying system saves your cleaning time.

k A.T.C. (ARMLESS Type) Tool to Tool

m A.T.C. (CHAIN Type) Tool to Tool

l A.T.C. (ARM Type) Tool to Tool
 BT40: 24/30 Tools, BT50: 24 Tools

h Chip Conveyor System Chain Type

o 2 Speed Gear Box for Spindles.

c Flood Coolant. (1HP: pressure 4kg/cm²)

p Spindle Cooling System.

i TS27R Tool Setting Probe.

g Coolant Thru Tool Tip.

r Laser Tool Measurement

Standard Coolant System x 2 pcs
 Air blast x 2 pcs

e Coolant Thru Spindle (2HP)(Pressure 20kg/cm²)

TORQUE POWER CHART

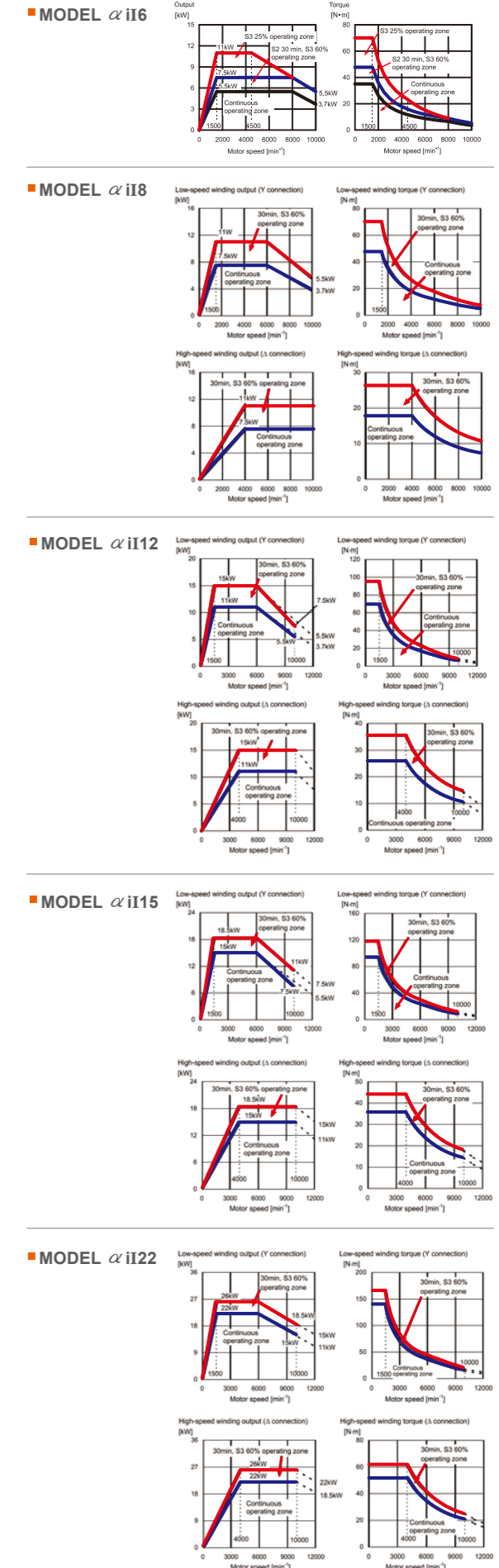

COMPUTER AIDED STRUCTURE DESIGN FOR PROCURING THE BEST RIGIDITY

- Six slideways on base for GMC-1890, 2090
- Four slideways on base for GMC-1680
- Averaged distributing heavy loading
- All 3 axes slideways are coated with **Turcite-B**.
- Supported by exceptional bearings and ball screws, which are pre-stressed to generate uniform axial as well as radial force distributions to provide high accuracy.
- With automatic screw type conveyor maintenance can be carried out easily.
- High precision ball screws on all three axes
O.D.50mm, Pitch12mm

MACHINE CONSTRUCTION FOR GMC-1890, 2090

Speedy and Reliable A.T.C

- BT50 / HSK-A100
- 24 Tools Arm Type (op)
Tool to Tool 2.5 Sec.
BT50
- 32 / 40 Tools Chain Type (op)
Tool to Tool 2.5 Sec.
BT50

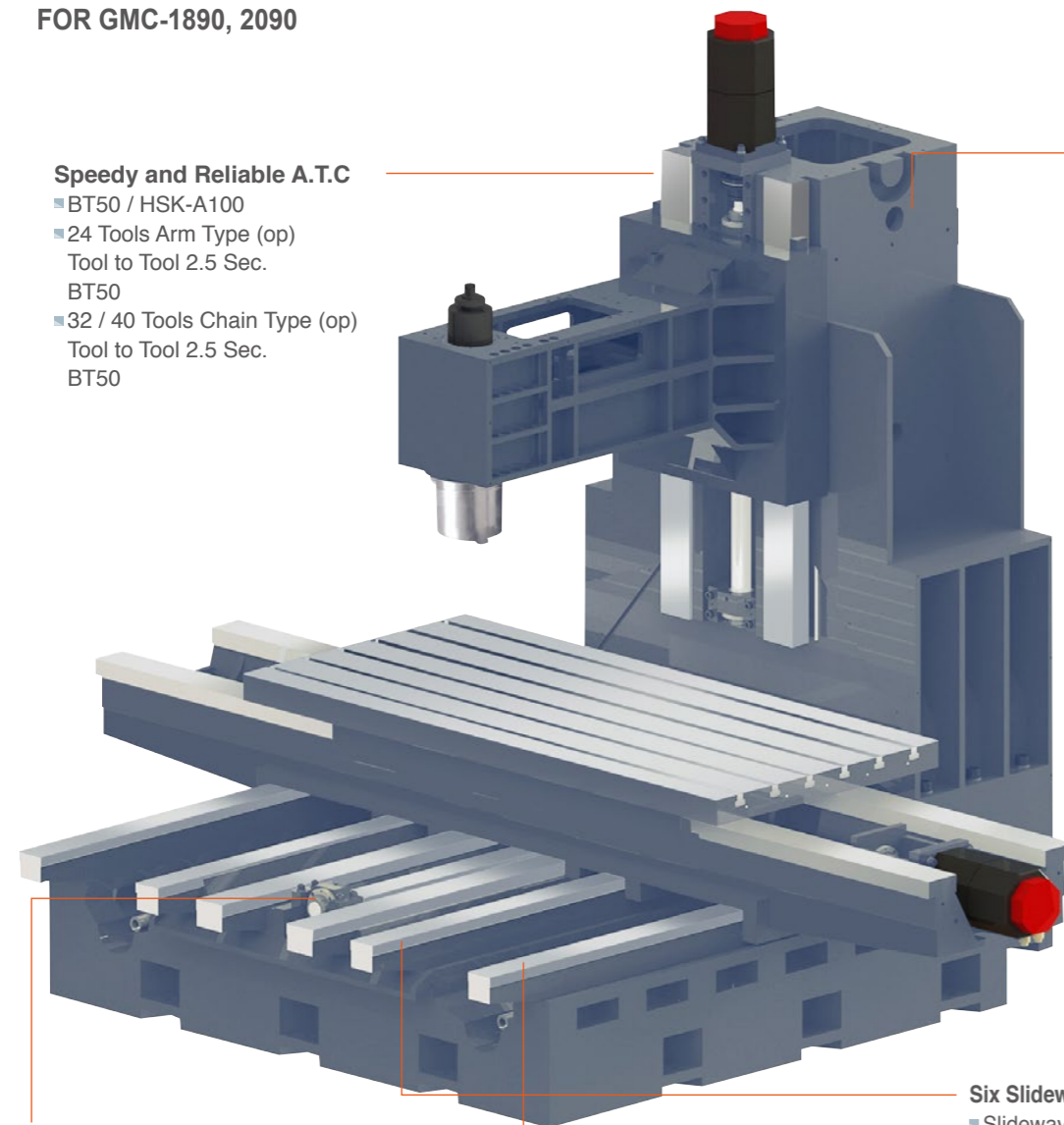

- #### Precision Ball Screws
- X,Y,Z-axis with preload large Dia.
50mm pitch 12mm (st) 16m/m (op)
 - Direct drive and Double nuts
 - Design provides to reduce friction heat and thermal growth to maintain rigidity, stability.

Hardening treatment
48°~52°

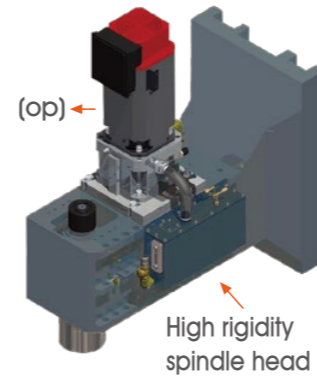

High rigidity spindle head

Spindle drive motor
(α 22i 2 Speed gear box)-1:4
560 NM
→ In low spindle speed 1,500rpm
140 NM
→ In high spindle speed 8,000~10,000rpm

Rigid Configuration Design

- Mighty **MEEHANITE** casting of all major components.
- Structure is analyzed by CATIA CAM and FEA (Finite Element Analysis)
- Strong Structure to extend rigidity, machining performance and long machine life

Six Slideways On Base

- Slideway surface has been processed hardening treatment then grind.
- When workpiece is offset, it will never twist, deflect, or warp load.
- Smooth traverse, Long machine life.
- Uniform weight distribution.
- Superior cutting performance.

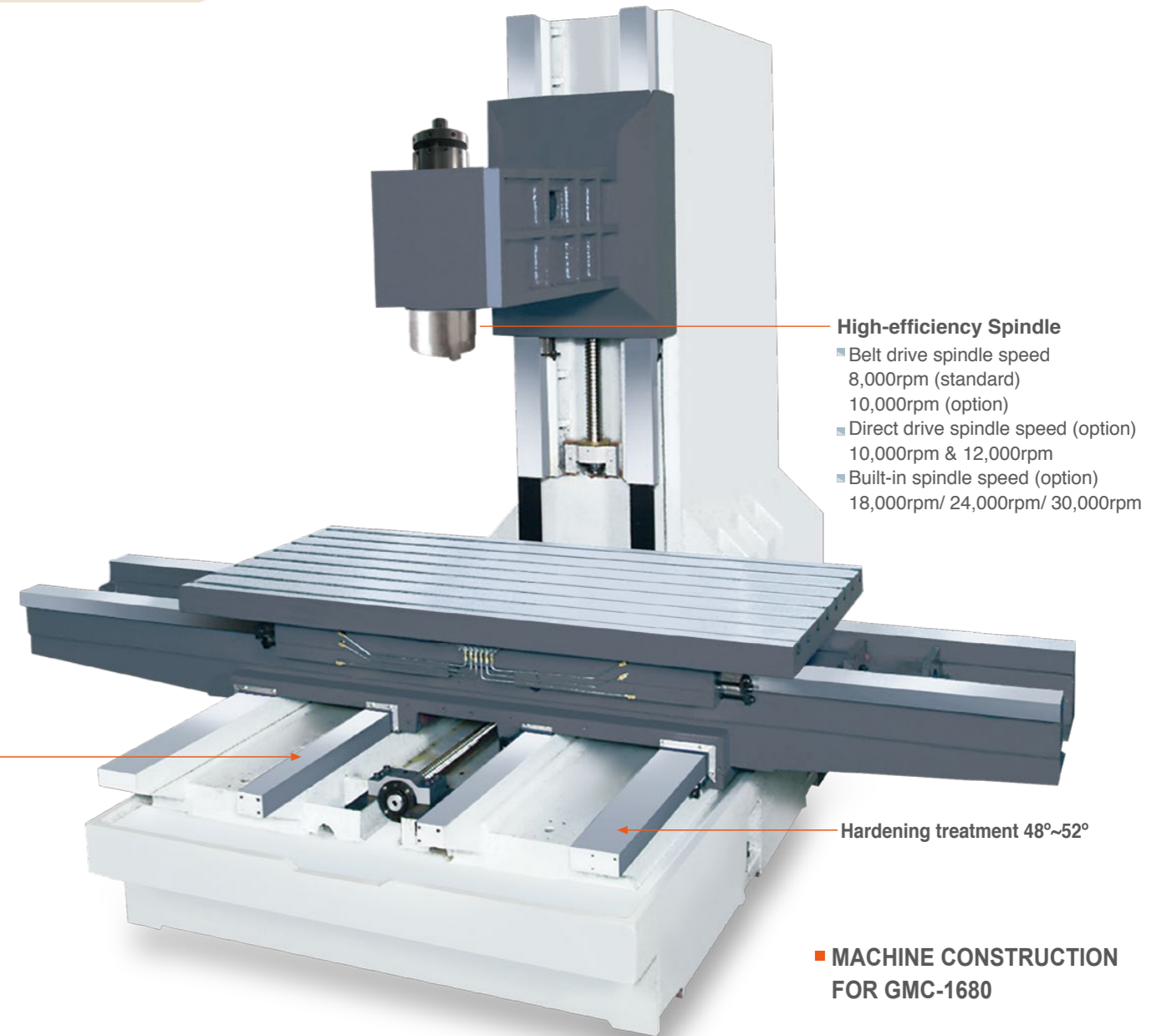

High-efficiency Spindle

- Belt drive spindle speed 8,000rpm (standard) 10,000rpm (option)
- Direct drive spindle speed (option) 10,000rpm & 12,000rpm
- Built-in spindle speed (option) 18,000rpm/ 24,000rpm/ 30,000rpm

Hardening treatment 48°~52°

MACHINE CONSTRUCTION FOR GMC-1680

FOUR SLIDWAYS ON BASE

- Slideway surface has been processed hardening treatment then grind.
- When workpiece is offset, it will never twist, deflect, or warp load.
- Smooth traverse, Long machine life.
- Uniform weight distribution.
- Superior cutting performance.

DIMENSION

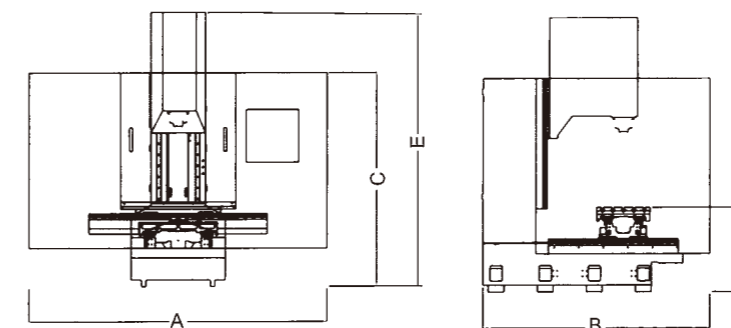

unit:cm

MODEL	GMC-860	GMC-1020	GMC-1100	GMC-1265
A	270	302	310	340
B	212	220	223	223
C	180	180	200	200
D	75	75	80	80
E(Belt/Direct Spindle)	272/282	310/320	310/320	310/320

MODEL	GMC-1465	GMC-1680	GMC-1880	GMC-2080
A	380	425	470	520
B	223	250	250	250
C	200	210	210	210
D	81	81	81	81
E(Belt/Direct Spindle)	320/330	320/330	330/340	330/340